

# Dampener Series

## Model. DS-1270 Series

# DAESHIN

### Summary

DS-1270 Series는 계기의 선택과 정확한 설치, 사용방법에 따라 압력계의 성능과 수명이 좌우되므로 압력계의 설치에 앞서 사용 목적에 적당한 Accessories로 선정하는 것이 매우 중요합니다. 가변 Type의 조임 장치인 Dampener (일종의 니들밸브)는 맥동압이 작용하는 곳에 압력계와 함께 취부하여 맥동에 의한 계기의 손상을 방지하기 위해 사용하며 설치 후, 압력계의 지시치를 적절히 조정하여 사용합니다.

### Purpose of Use

- ▶ 맥동압이 작용하는 장소
- ▶ Oil이 들어가면 안되는 곳
- ▶ 과압 및 기포제거
- ▶ 배관의 배출구(Air Vent Plug)용

### Material

Brass  
Stainless Steel

### Test Pressure

30 Mpa

### Maximum Working Pressure

20 Mpa

### Maximum Working Temperature

200 °C



Model. DS-1272

## Standard features

### Body

Brass - BSBM  
Steel - STS 316

### Joint

Brass - SS41 (Ni-Plating)  
Steel - STS 316

### Stopper

Brass - STS 316  
Steel - STS 316

### Washer

Brass - BSBM  
St, St - STS 316

### Gasket Outlet

Brass - Teflon  
St, St - Teflon

### Retaining Screw

Brass - SS41 (Ni-Plating)  
St, St - SS41 (Ni-Plating)

Pressure Gauge

Accessories

Thermometer

Thermocouple  
& R.T.D

Thermowell

# Dampener Series

## Model. DS-1270 Series

# DAESHIN

### Model. DS-1271 Dampener (Female x Male)

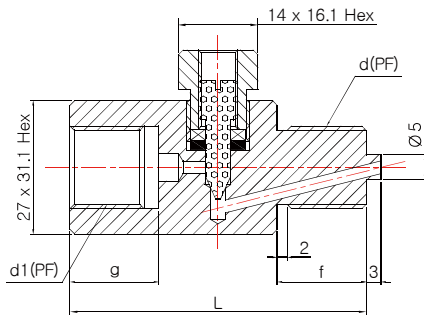

#### Dimensions (mm)

Model No.	Con'n(d1)	Con'n(d)	g	k	L
DAMPENER (PF x PF)	PF 1/4	PF 1/4	16	16	56
	PF 1/4	PF 3/8	16	18	58
	PF 1/4	PF 1/2	16	20	60
	PF 3/8	PF 1/4	18	16	58
	PF 3/8	PF 3/8	18	18	60
	PF 3/8	PF 1/2	18	20	62
	PF 1/2	PF 1/4	20	16	60
	PF 1/2	PF 3/8	20	18	62
PF 1/2	PF 1/2	20	20	64	

### Model. DS-1272 Dampener (Female x Male)

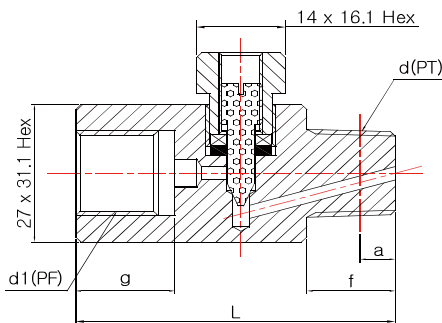

#### Dimensions (mm)

Model No.	Con'n(d1)	Con'n(d)	g	k	L
DAMPENER (PF x PT)	PF 1/4	PT 1/4	16	16	54
	PF 1/4	PT 3/8	16	18	56
	PF 1/4	PT 1/2	16	20	58
	PF 3/8	PT 1/4	18	16	56
	PF 3/8	PT 3/8	18	18	58
	PF 3/8	PT 1/2	18	20	60
	PF 1/2	PT 1/4	20	16	58
	PF 1/2	PT 3/8	20	18	60
PF 1/2	PT 1/2	20	20	62	

### Model. DS-1273 Dampener (Female x Male)

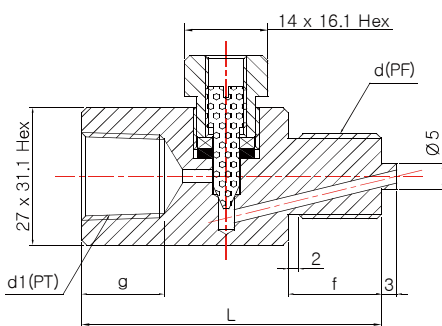

#### Dimensions (mm)

Model No.	Con'n(d1)	Con'n(d)	g	k	L
DAMPENER (PT x PF)	PT 1/4	PF 1/4	14	16	54
	PT 1/4	PF 3/8	14	18	56
	PT 1/4	PF 1/2	14	20	58
	PT 3/8	PF 1/4	16	16	56
	PT 3/8	PF 3/8	16	18	58
	PT 3/8	PF 1/2	16	20	60
	PT 1/2	PF 1/4	18	16	58
	PT 1/2	PF 3/8	18	18	60
	PT 1/2	PF 1/2	18	20	62

### Model. DS-1274 Dampener (Female x Male)

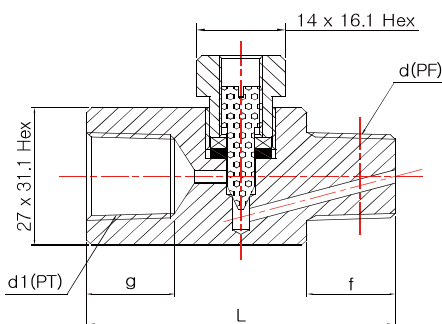

#### Dimensions (mm)

Model No.	Con'n(d1)	Con'n(d)	g	k	L
DAMPENER (PT x PT)	PT 1/4	PT 1/4	14	14	56
	PT 1/4	PT 3/8	14	16	58
	PT 1/4	PT 1/2	14	18	60
	PT 3/8	PT 1/4	16	14	58
	PT 3/8	PT 3/8	16	16	60
	PT 3/8	PT 1/2	16	18	62
	PT 1/2	PT 1/4	18	14	60
	PT 1/2	PT 3/8	18	16	62
	PT 1/2	PT 1/2	18	18	64

Pressure Gauge

Accessories

Thermometer

Thermocouple & R.T.D

Thermowell